

This form is your authorisation for us to proceed with manufacturing your order. To ensure that we make exactly what you require, please take time to check the items that we have quoted - if there is anything that you are unsure about concerning this order, please contact us before signing this form.

This form can be completed on-line: www.bungalowandvilla.co.nz/jobauth/php.

Work on your order will not commence until this form is completed and returned to us.

Customer's Name: _____ Account Number (if applicable) _____

Address: _____

Site Address (if Different): _____

Telephone: (Home) _____ (Work) _____ (Mobile) _____

Email: _____ Fax: _____

The best way to contact me is by _____ Quote or Sales Order Number _____

Brief Description of work to be undertaken: _____

Lead Times: Our normal lead time for joinery products is 4 weeks. Depending on the nature of the product, it may take longer, especially during periods of high demand. Please confirm the expected completion date at the time of order.

Returns & Cancellations: Please ensure that you have read the section in our product guide about returning goods & cancelling orders.

Warranty: By signing below, you are accepting our Warranty Terms & Conditions. They are printed on the reverse. Please take time to read them.

Total Value of Order (at time or order placement): _____ Deposit Required: _____

Payments & Deposits:

Non Credit Account Holders

All orders for Made to Order products require a 40% deposit to be paid at the time of order. The deposit will be allocated against the final balance of the order. The balance of payment will be required prior to collection / delivery.

Credit Account Holders

If you have a credit account, you will not be required to pay a deposit unless the value of the order exceeds your credit limit. The balance of payment would be due under the terms of your credit account.

Signed & Accepted by Customer/Account Holder _____ Date _____

You can return the completed form to Bungalow & Villa,
in person to: 11 McDonald Street Morningside, Auckland
by post to: Bungalow & Villa
PO Box 78073
Grey Lynn
or by fax to: 09 846 1503

We accept the following methods of payment:

Cash

Cheque

Eftpos/Credit Card (Visa or Master Card only)

Bank Direct Credit

Bungalow & Villa Bank Account Details:

03-0228-0206013-00

When paying by Bank Direct Credit, please put the Quote number and/or your name in the reference boxes.

For Office Use Only:

Job Authorisation Form Signed

Quote/Sales Order Number

Account Type

Deposit Required (Y or N)

Deposit Received (Y or N)

Method of Payment

Quoted Delivery Date

Sales Person Signature

Approved by Factory Manager

Date

IMPORTANT INFORMATION

It is important to ensure that your Timber Joinery or other Timber products receive the correct care and finishing required following collection or delivery to site. **Please observe the following instructions to obtain the best possible performance from your purchase.**

A: Site Storage

Exterior Joinery: Always store Joinery units upright and in a dry ventilated environment.

Un-primed Joinery products require at least one coat of an oil-based primer immediately upon reaching site

Prior to storage.

Interior Joinery & Other Timber Products: Always store Interior Joinery upright in a dry ventilated environment away from direct sunlight and heat sources. Special care should be taken on sites with heavy masonry content (i.e concrete block / slab) construction. Moisture from surrounding masonry will be absorbed by raw timber products, compromising dimensional stability of joinery components. Also excessive heat sources (i.e direct sunlight, closed dry rooms) with no ventilation will have a similar effect on dimensional stability through evaporating moisture content from within the timber components.

B: Prime / Seal

Exterior Joinery: B & V recommends purchasing all exterior Joinery products Factory Primed / Sealed.

Use only premium quality oil-base alkyd primers and sealers. Within 4 weeks of receiving your joinery you will need to apply a minimum of two successive coats (preferably oil-based enamels) to all primed surfaces, paying special attention to all 'End grain' areas, usually the tops and bottoms of doors and window sashes, (see right).

This area is where a large percentage of moisture uptake occurs and causes the most common of problems: Swelling, shrinkage and joint failure.

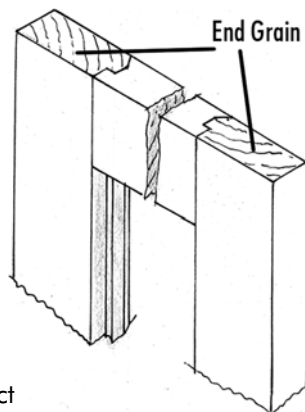

Interior Joinery: For un-primed Joinery, prime **all faces of all timber surfaces** immediately upon the product reaching site, and follow on with the procedures outlined above as for exterior joinery.

C: Installation

All B & V Joinery products require installation by trade qualified personnel. Incorrect installation will result in disappointing and poor performance along with a shortened life expectancy of the product concerned. Incorrect installation can lead to the assumption that the joinery product is defective which in most cases is incorrect.

Any installation instructions provided must be followed at all times.

D: Intended Use

Please ensure that the joinery or renovation product that you are purchasing is suitable for the intended end use. Some Joinery will perform better and last longer in certain locations (i.e panel doors generally will not perform well in weather exposed locations etc). **Placing a joinery unit in an unsuitable location may Void your Warranty.**

Please ask for advice before placing your order if you are unsure about the best product for your particular application.

Bungalow & Villa aims to manufacture and supply a quality joinery product. Failure to follow the recommendations outlined above may result in product failure and void any Warranty offered.

Warranty

All products supplied by Bungalow & Villa are guaranteed to be of good workmanship & materials and free from defects for a period of twelve (12) months from the date of manufacturer. Bungalow & Villa will provide remedial work to correct any defects that develop due to faulty materials or workmanship.

No liability will be accepted where problems or damage occurs from the following conditions:

Intended Use: Exterior panel type doors are designed for use only in weather protected situations and should not be subjected to prolonged periods of direct sunlight or driving rain.

Installation: Where faults, poor performance or damage to the product which can be attributed to incorrect installation of the product, warranty claims will not be entertained.

Priming / Sealing: All surfaces (including tops and bottoms of door leaves & window sashes) need to be primed and sealed prior to installation of the product. Warranty claims will not be accepted where the product has not been primed/painted as described in the Important Information section above.

Paint Colours: Warranty claims for damage/distortion of the product due to being painted in a dark colour where the product is exposed to direct or indirect sunlight, will not be accepted.

Remedial Work: Remedial work carried out under the terms of this warranty does not include painting.

Please note that our full 'Terms and Conditions of Trade' are available upon request.