

QUOTE ACCEPTANCE FORM (august 2016)

This form is your authorisation for us to proceed with manufacturing your order. To ensure that we make exactly what you require, please take time to check the items that we have quoted. If there is anything that you are unsure about concerning this order, please contact us before signing this form.

**You can also complete this form online by visiting <http://www.bungalowandvilla.co.nz/quote-acceptance>
Work on your order will not commence until this form is completed and returned to us.**

Customer's name:	Land line number (if applicable):	Total value of order at time of order placement:
Account number (if applicable):	email:	Deposit required:
Site address:	Quote number (including revision no):	Brief description of order:
Mobile number:		

IMPORTANT INFORMATION: PLEASE READ *(more overleaf)*

Lead Times:

The lead time for your order will depend on the type of product you have ordered and the size of the order. When we quote for your job, we will give a verbal indication of the lead time. We will confirm this once you have placed your order.

Returns & Cancellations:

By signing this form you are accepting our Returns & Cancellation policy. It can be found on our website.

Warranty:

By signing this form you are accepting our Warranty terms & conditions which can be found on our website

Painting and colours:

Although your joinery will already have a coat of primer, it will require a minimum of 2 further coats of paint, paying particular attention to end grain areas. Avoid dark colours as they can encourage resin bleed and distortion. Top coats should have a paint colour value of LRV45 or higher.

Payments & Deposits:

All orders for made to order goods require a 40% deposit to be paid at the time of order. We require the full balance to be paid before delivery or collection of the order. (Account customers are not required to pay a deposit unless the value of the order is greater than the credit limit.)

Changes to your order:

Any changes to your order must be made in writing and may be subject to a re-quote. This may also affect the quoted delivery time

Price changes:

This price is valid for two months from acceptance of quote as price of materials are subject to change at short notice. We will be in contact if a requote is required.

Cancellation of order by Bungalow & Villa:

Bungalow & Villa reserves the right to cancel this order due to unforeseen circumstances that affect our ability to reasonably manufacture and supply this order.

I authorise Bungalow & Villa/B&V Timber Joinery to proceed with manufacturing my order as indicated above. I have read and accept the 'Important Information' as outlined above and further terms of service as detailed on the second page of this form.

Signed _____ Date _____

You can return this form to us in the following ways:

Scan and email: info@bungalowandvilla.co.nz
Online form: bungalowandvilla.co.nz/quote-acceptance
You will be given different options for paying your deposit, including by credit card online.
Fax: 09 846 1503
Post: Bungalow & Villa
 PO Box 78-073
 Grey Lynn, Auckland, 1245

You can make payments to us in the following ways:

Online banking: Bungalow & Villa account number: 03-0228-0206013-00. Please put your Quote number and your name in the reference boxes

**Eftpos/Visa/Mastercard
Cheque or Cash**

For Bungalow & Villa use	
<i>These boxes must be complete before production can commence</i>	
Quote Acceptance form signed?	<input type="checkbox"/>
Sales order number	<input type="text"/>
Account type	<input type="text"/>
Deposit required? (Y or N)	<input type="checkbox"/>
Deposit Paid? (Y or N)	<input type="checkbox"/>
Method of payment	<input type="text"/>
Delivery or collection	<input type="text"/>
Quoted delivery date	<input type="text"/>
Sales person signature	<input type="text"/>
Approved by Production Manager	<input type="text"/>
Date	<input type="text"/>

IMPORTANT INFORMATION

It is important to ensure that your Timber Joinery or other Timber products receive the required care and finishing following collection or delivery to site. **Please observe the following instructions to obtain the best possible performance from your purchase.**

Site Storage

Exterior Joinery: Always store Joinery units upright and in a dry ventilated environment.

Un-primed Joinery products require at least one coat of an oil-based primer immediately upon reaching site and prior to storage.

Interior Joinery & Other Timber

Products: Always store Interior Joinery upright in a dry ventilated environment away from direct sunlight and heat sources. Special care should be taken on sites with heavy masonry content (i.e. concrete block / slab) construction. Moisture from surrounding masonry will be absorbed by raw timber products, compromising dimensional stability of joinery components. Also excessive heat sources (i.e. direct sunlight, closed dry rooms) with no ventilation will have a similar effect on dimensional stability through evaporating moisture content from within the timber components.

Installation

All B & V Joinery products require installation by trade qualified personnel. Incorrect installation will result in disappointing and poor performance along with a shortened life expectancy of the product concerned. Any installation instructions provided must be followed at all times.

Intended Use

Please ensure that the joinery or renovation product that you are purchasing is suitable for the intended end use. Some Joinery will perform better and last longer in certain locations (i.e. panel doors generally will not perform well in weather exposed locations etc). **Placing a joinery unit in an unsuitable location may void your Warranty.**

Please ask for advice before placing your order if you are unsure about the best product for your particular application.

Prime / Seal

Exterior Joinery: Bungalow & Villa recommends purchasing all exterior Joinery products Factory Primed / Sealed.

Use only premium quality oil-base alkyd primers and sealers. Within 4 weeks of receiving your joinery you will need to apply a minimum of two successive coats (preferably oil-based enamels) to all primed surfaces, paying special attention to all 'End grain' areas, usually the tops and bottoms of doors and window sashes, (see below).

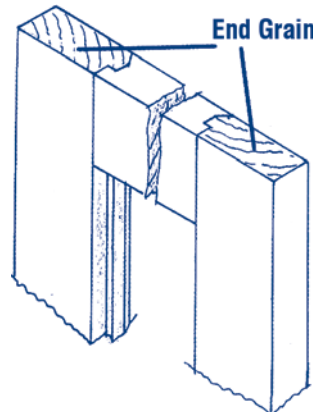

This area is where a large percentage of moisture uptake occurs and causes the most common problems: Swelling, shrinkage and joint failure.

Interior Joinery: For un-primed Joinery, prime **all faces of all timber surfaces** immediately upon the product reaching site, and follow on with the procedures outlined above for exterior joinery.

Failure to follow the recommendations outlined above may result in product failure and void any Warranty offered. If you have any questions about the suitability of what you are ordering please contact us prior to accepting your quote.

Warranty

All products supplied by Bungalow & Villa are guaranteed to be of good workmanship & materials and free from defects for a period of twelve (12) months from the date of manufacture. Bungalow & Villa will provide remedial work to correct any defects that develop due to faulty materials or workmanship.

No liability will be accepted where problems or damage arises from non compliance with the following:

Intended Use:

Exterior panel type doors are designed for use only in weather protected situations and should not be subjected to prolonged periods of direct sunlight or driving rain.

Installation:

The product should be installed in line with best trade practice.

Priming / Sealing:

All surfaces (including tops and bottoms of door leaves & window sashes) need to be primed and sealed prior to installation of the product.

Paint Colours:

The product should not be painted in a dark colour. Top coats should have a paint colour value of LRV45 or higher.

Remedial Work:

Remedial work carried out under the terms of this Warranty does not include painting.